

SHOREBLOCK® MAT ASSEMBLY DETAIL  
N.T.S.

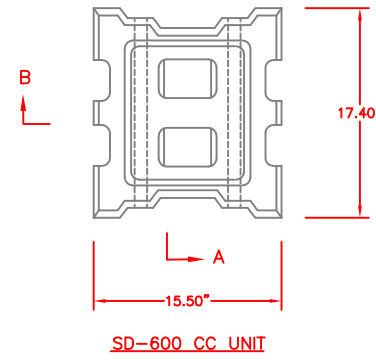

SD-600 CC UNIT

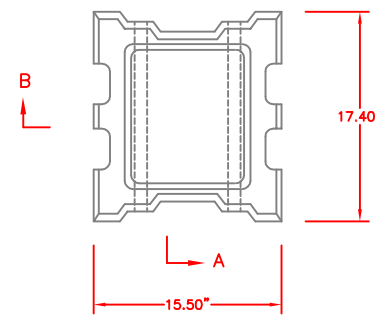

SD-600 CC UNIT

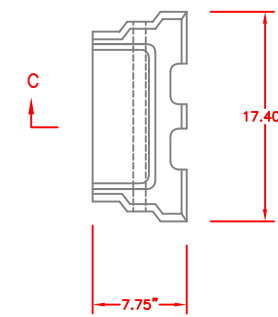

HALF BLOCK UNIT

- TECHNICAL SPECIFICATIONS**
- SHOREBLOCK® UNITS ARE MANUFACTURED IN ACCORDANCE WITH ASTM C90 AND C140 AND THE FOLLOWING CRITERIA:
    - CONCRETE UNIT WEIGHT 130 -150 LBS/CF
    - MINIMUM COMPRESSIVE STRENGTH - 4,000 PSI.
    - MAXIMUM ABSORPTION - 5 %
    - DIMENSIONAL TOLERANCE ± 1/8"
  - GALVANIZED OR POLYESTER CABLING

- ASSEMBLY SPECIFICATIONS**
- SHOREBLOCK® UNITS ARE SHOP ASSEMBLED IN A CABLED MATTERESS AS SHOWN ABOVE.
  - SHOREBLOCK® MATS ARE PLACED BY THE CONTRACTOR IN THE FIELD ON PREPARED SLOPES PER THE CONTRACT DRAWINGS.

UNIT	UNIT WEIGHT LBS.	SYSTEM WEIGHT (lbs/sq.ft)	OPEN AREA
SD-600 OC	81 - 88	46 - 50	20%
SD-600 CC	94 - 101	53 - 57	10%

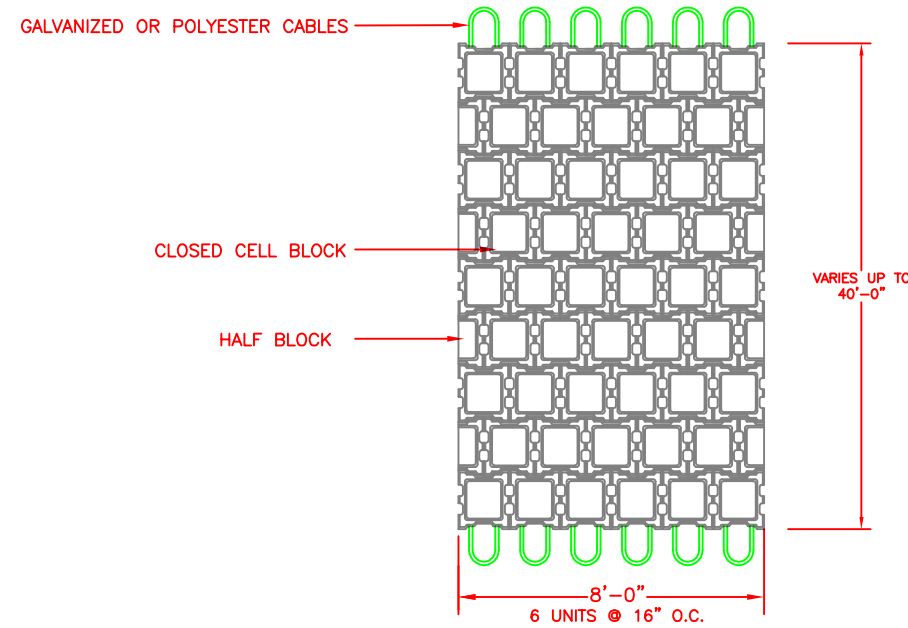

SHOREBLOCK® MAT ASSEMBLY DETAIL  
N.T.S.

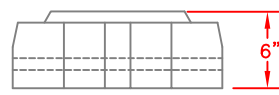
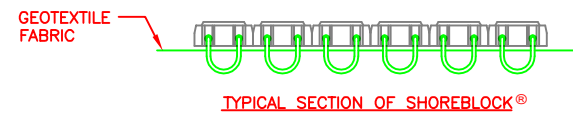

TYPICAL SECTION A

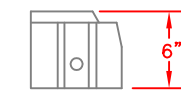

TYPICAL SECTION C

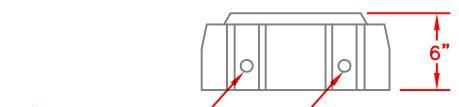

1" CABLE DUCT  
TYPICAL SECTION B

**SHORETEC® L.L.C.**

510 O'NEAL LANE  
Baton Rouge, Louisiana 70819  
(225) 408-1444 - Phone  
(225) 408-1445 - Fax  
www.shorettec.com

Client:		
Scale:	Drawn By:	File Name:
N.T.S.	A. CASE	

Title:	
SHOREBLOCK® SD SERIES SD-600 OPEN AND CLOSED CELL	
Project No:	Drawing No:
	54

No.	Date	Revision	By

DISCLAIMER  
THE INFORMATION CONTAINED HEREIN HAS BEEN COMPILED BY SHORETEC® LLC AND TO THE BEST OF OUR KNOWLEDGE, ACCURATELY REPRESENTS THE SHOREBLOCK® PRODUCT USE IN THE APPLICATIONS WHICH ARE ILLUSTRATED. FINAL DETERMINATION OF THE SUITABILITY FOR THE USE CONTEMPLATED AND ITS MANNER OF USE ARE THE SOLE RESPONSIBILITY OF THE USER. STRUCTURAL DESIGN AND ANALYSIS SHALL BE PERFORMED BY A QUALIFIED ENGINEER.

THIS DRAWING IS BEING FURNISHED FOR THIS SPECIFIC PROJECT ONLY. ANY PARTY ACCEPTING THIS DOCUMENT DOES SO IN CONFIDENCE AND AGREES THAT IT SHALL NOT BE DUPLICATED IN WHOLE OR IN PART, NOR DISCLOSED TO OTHERS WITHOUT THE CONSENT OF SHORETEC® L.L.C..